



Refrigeration SMART Undercounter 3 Door Freezer

ITEM # _____
 MODEL # _____
 PROJECT NAME # _____
 SIS # _____
 AIA # _____



Refrigeration SMART Undercounter 3 Door Freezer

726686 (RCEF3M3U) 15.5 ft³ Full Size
 Undercounter Freezer -
 3 door 115 V/1p/60Hz

Short Form Specification

Item No. _____

The Electrolux range of freezer counters combines the convenience of worktop space with cold storage located below. This range of counters is manufactured throughout in AISI 304 stainless steel to meet the highest hygiene standards. The range comprises three sizes of counter, with built-in compressor units, in various door and drawer configurations and in refrigerator or freezer versions. The model detailed on this sheet benefit from the advantages of smart electronic control. It has two full doors and operates over the temperature range of -5 °F to -11 °F (-15 °C to -24 °C).

Main features

EASY TO INSTALL

- Mounted on legs with height adjustment.
- Built-in compressor to suit operating conditions.
- Suitable for use in ambient temperatures of up to 109 °F (43 °C).
- Touch pad selection for the five most common food stuffs the smart electronic control sets the appropriate temperature and humidity.

EASY TO CLEAN

- Constructed from AISI 304 stainless steel throughout to meet the highest hygiene standards.
- Rounded internal corners for ease of cleaning.
- Mounted on stainless steel legs to give 6" (150 mm) clearance for ease of cleaning the floor.
- The SMART defrosting cycle only starts if it is necessary (by checking the intensity of ice on the evaporator).

EASY TO USE

- Adjustable temperature range from -5 °F to -11.2 °F (-15 °C to -24 °C) to suit meat, fish and dairy storage requirements.
- Anti-tilt runners accept GN1/1 containers.
- Electronic microprocessor control with external digital temperature display.
- Forced air circulation for rapid cooling and an even temperature distribution.
- HACCP incorporated - all events are recorded, displaying, date and time.
- A memory function keeps the information for working even when a probe failed.
- Worktop in AISI 304 stainless steel with a 2" (50 mm) thickness.

EASY TO MAINTAIN

- Access to all components from the front.
- In compliance with ETL requirements.
- Fault code display.

EASY ON THE ENVIRONMENT

- CFC and HCFC free (ecological refrigerant type: R404a, - gas in foam: cyclopentane).
- 2.36" (60 mm) insulation for energy saving.
- Less on energy consumption due to smart defrosting cycles.
- Developed and produced in ISO 9001 and ISO 14001 certified factory.

Included Accessories

- 1/1 GN grey Rilsan® grid (PNC 881435)

Optional Accessories

- Plastic container GN 1/1 H = 3.93" (100 mm) (PNC 811451)
- Top panel (flat) for 3-door HD tables (PNC 880154)
- Kit 2 drawers 1/2 + rack-ref. counters (PNC 880156)
- Kit 3 drawers 1/3 + rack-ref. counters (PNC 880157)
- Kit 1 bottler + 1 drawer-ref. counter (PNC 880158)
- Plastic container GN 1/1 H = 2.55" (65 mm) (PNC 881038)
- Plastic container GN 1/1 H = 6.0" (150 mm) (PNC 881040)
- 1/1 GN grey Rilsan® grid (PNC 881435)
- Lock for refrigerated counter (PNC 881499)



Approval: _____

Electrolux Professional, Inc.

www.electroluxusa.com/professional

3225 SW 42nd Street, Fort Lauderdale, Florida, 33312 • Telephone Number: 866-449-4200 • Fax Number: 954-327-6789



Front View

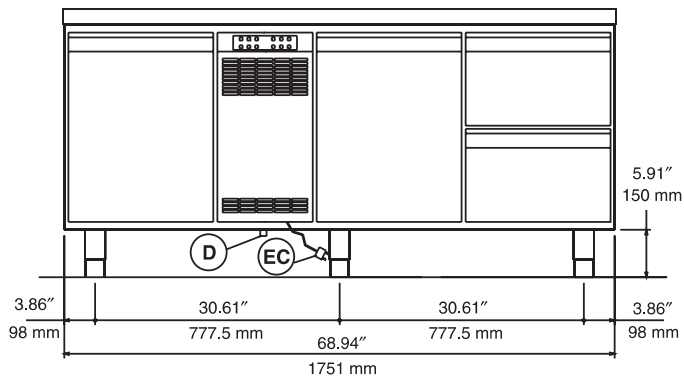

Top View

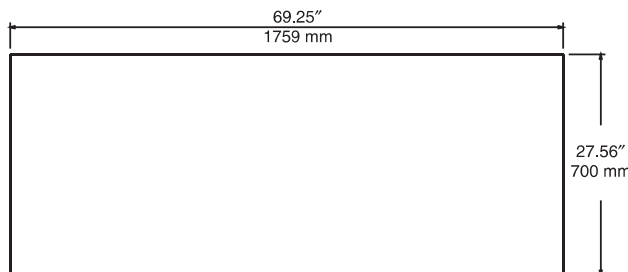

EC = Electrical connection
D = Water drain

Side View

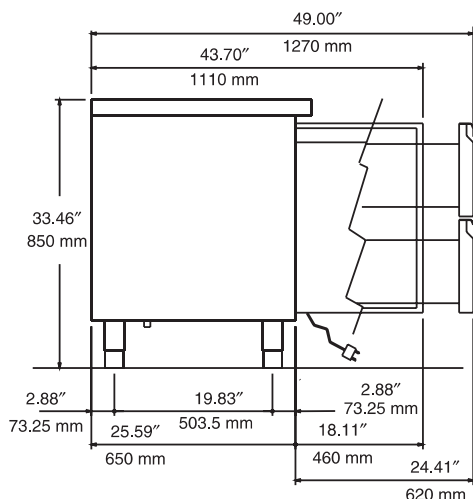

Electric

Supply voltage: 726686 (RCEF3M3U) 115 V/1p/60Hz - 10A

Key Information

LEGEND

C - Water Drain: 0.63" (16 mm)
I - Electrical Connection: 115 V/1p/60Hz

TECHNICAL DATA

Built-in Compressor and Refrigeration Unit

External Dimensions

Width: 69.25" (1759 mm)
Depth: 27.56" (700 mm)
Depth/with doors open: 43.70" (1110 mm)
Height/with legs fully extended: 35.46" (900 mm)

Min/Max internal humidity %: 80/ 95

Number and type of doors: 3 Full

Door hinges: 1 Left + 2 Right

Number and type of grids (included): 3, GN 1/1

Compressor power: 3/4 HP

Refrigerant type: R404a

Refrigerant quantity: 5.36 oz (280g)

Refrigerant Power: 925W

Power: 800 watts

Net weight: 335 lb (152 kg)